

2" Heavy Duty Swing Check with Flow Indicator A7616

Application

This back check valve is designed to provide required back flow protection for the unloading riser in the bulk plant's transfer area. It is designed specifically for pipeline installation and is suitable for LP-Gas and anhydrous ammonia service. Product flow moves the swing check to the open position, when flow stops the spring loaded swing check closes.



A7616

Features

- Easy-to-read flow indicator
- Heavy duty spring loaded swing check design
- Resilient synthetic rubber seat disc
- High flow rates with low pressure drop
- May be installed either horizontally or vertically
- 1/4" F.NPT plugged boss on top of body



Materials

Body Ductile Iron
 Stem Stainless Steel
 Seat Stainless Steel
 Seat Disc Synthetic Rubber
 Return Spring Stainless Steel

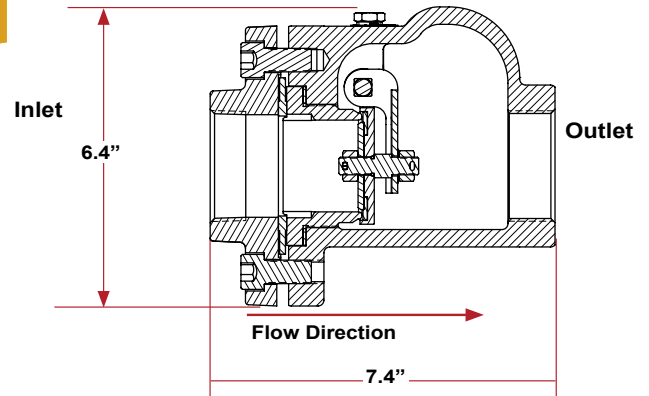

Ordering Information

Part Number	For Use With:	Inlet & Outlet Connections	Liquid Capacity at 10 PSIG Drop GPM
A7616	LPG & NH3	2" F.NPT	711-GPM(LPG) 640-GPM(NH3)