

Double Check Low Emission Filler Valves for Forklift and DOT Containers 7647 Series

Application

Designed to provide fast filling of forklift, motor fuel, and recreational vehicle tanks.



Features

- Resilient seat disc in lower check designed to provide a gas tight seal without leakage.
- Double back check provides added system protection.
- 7647SA has 30° angle on hose connection. Makes connection and disconnection easier for certain engine fuel applications.
- Large 1 3/4" wrench flats on 7647SC allow use of socket wrench for easy installation.
- Specify RegO Filler Valves on all your original tank purchases to ensure quality and dependable performance.

Materials

Upper Body.....	Brass
Lower Body.....	Brass
Springs	Stainless Steel
Washer and Seat Discs	Resilient Synthetic Rubber
Cap	Plastic

Lanyard and Cap



7647SC

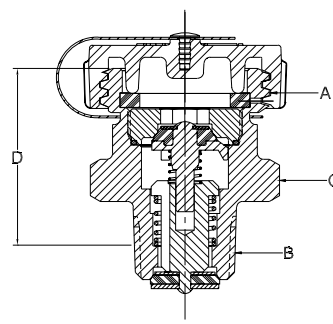

7647DC

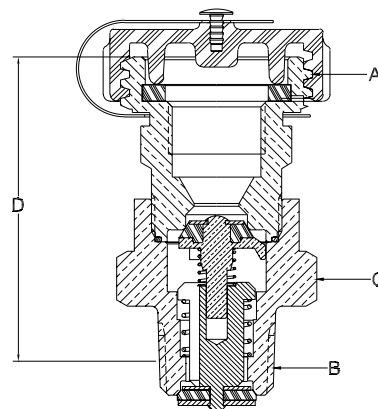

Ordering Information

Part Number	A Hose Connection	B Tank Connection M. NPT	C Wrench Flats	D Effective Length (Approx.)	Propane Liquid Capacity at Various Differential Pressures (GPM)**				
					10 PSIG	20 PSIG	30 PSIG	40 PSIG	50 PSIG
7647DC	1 3/4" ACME + F. POL	3/4"	1 5/8"	2 9/16"	14	20	24	27	50
7647SC*	1 3/4" ACME		1 3/4"	1 11/16"					

* Large 1 3/4" hex wrench flats.

** Multiply flow rate by .94 to determine liquid butane capacity.